

# 74HC164; 74HCT164

## 8-bit serial-in, parallel-out shift register

Product data sheet

### 1. General description

The 74HC164; 74HCT164 are high-speed Si-gate CMOS devices and are pin compatible with Low power Schottky TTL (LSTTL). They are specified in compliance with JEDEC standard no. 7A.

The 74HC164; 74HCT164 are 8-bit edge-triggered shift registers with serial data entry and an output from each of the eight stages. Data is entered serially through one of two inputs (DSA or DSB); either input can be used as an active HIGH enable for data entry through the other input. Both inputs must be connected together or an unused input must be tied HIGH.

Data shifts one place to the right on each LOW-to-HIGH transition of the clock (CP) input and enters into Q0, which is the logical AND of the two data inputs (DSA and DSB) that existed one set-up time prior to the rising clock edge.

A LOW level on the master reset ( $\overline{\text{MR}}$ ) input overrides all other inputs and clears the register asynchronously, forcing all outputs LOW.

### 2. Features

- Gated serial data inputs
- Asynchronous master reset
- Complies with JEDEC standard no. 7A
- ESD protection:
  - ◆ HBM EIA/JESD22-A114-B exceeds 2000 V
  - ◆ MM EIA/JESD22-A115-A exceeds 200 V.
- Multiple package options
- Specified from  $-40\text{ }^{\circ}\text{C}$  to  $+85\text{ }^{\circ}\text{C}$  and  $-40\text{ }^{\circ}\text{C}$  to  $+125\text{ }^{\circ}\text{C}$ .

### 3. Quick reference data

**Table 1: Quick reference data**  
 $GND = 0\text{ V}$ ;  $T_{amb} = 25\text{ }^{\circ}\text{C}$ ;  $t_r = t_f = 6\text{ ns}$ .

Symbol	Parameter	Conditions	Min	Typ	Max	Unit
<b>Type 74HC164</b>						
$t_{\text{PHL}}$ , $t_{\text{PLH}}$	propagation delay					
	CP to Qn	$C_L = 15\text{ pF}$ ; $V_{\text{CC}} = 5\text{ V}$	-	12	-	ns
	$\overline{\text{MR}}$ to Qn	$C_L = 15\text{ pF}$ ; $V_{\text{CC}} = 5\text{ V}$	-	11	-	ns

**PHILIPS**

**Table 1: Quick reference data ...continued**

$GND = 0\text{ V}$ ;  $T_{amb} = 25\text{ °C}$ ;  $t_r = t_f = 6\text{ ns}$ .

Symbol	Parameter	Conditions	Min	Typ	Max	Unit
$f_{max}$	maximum clock frequency	$C_L = 15\text{ pF}$ ; $V_{CC} = 5\text{ V}$	-	78	-	MHz
$C_I$	input capacitance		-	3.5	-	pF
$C_{PD}$	power dissipation capacitance per package		[1] [2]	40	-	pF
<b>Type 74HCT164</b>						
$t_{PHL}, t_{PLH}$	propagation delay					
	CP to Qn	$C_L = 15\text{ pF}$ ; $V_{CC} = 5\text{ V}$	-	14	-	ns
	$\overline{MR}$ to Qn	$C_L = 15\text{ pF}$ ; $V_{CC} = 5\text{ V}$	-	16	-	ns
$f_{max}$	maximum clock frequency	$C_L = 15\text{ pF}$ ; $V_{CC} = 5\text{ V}$	-	61	-	MHz
$C_I$	input capacitance		-	3.5	-	pF
$C_{PD}$	power dissipation capacitance per package		[1] [3]	40	-	pF

[1]  $C_{PD}$  is used to determine the dynamic power dissipation ( $P_D$  in  $\mu\text{W}$ ).

$$P_D = C_{PD} \times V_{CC}^2 \times f_i \times N + \sum (C_L \times V_{CC}^2 \times f_o) \text{ where:}$$

$f_i$  = input frequency in MHz

$f_o$  = output frequency in MHz

$N$  = number of inputs switching

$\sum (C_L \times V_{CC}^2 \times f_o)$  = sum of outputs

$C_L$  = output load capacitance in pF

$V_{CC}$  = supply voltage in Volts

[2] For HC the condition is  $V_I = GND$  to  $V_{CC}$ .

[3] For HCT the condition is  $V_I = GND$  to  $V_{CC} - 1.5\text{ V}$ .

## 4. Ordering information

**Table 2: Ordering information**

Type number	Package			Version
	Temperature range	Name	Description	
74HC164N	-40 °C to +125 °C	DIP14	plastic dual in-line package; 14 leads (300 mil)	SOT27-1
74HC164D	-40 °C to +125 °C	SO14	plastic small outline package; 14 leads; body width 3.9 mm; body thickness 1.47 mm	SOT108-2
74HC164DB	-40 °C to +125 °C	SSOP14	plastic shrink small outline package; 14 leads; body width 5.3 mm	SOT337-1
74HC164PW	-40 °C to +125 °C	TSSOP14	plastic thin shrink small outline package; 14 leads; body width 4.4 mm	SOT402-1
74HCT164N	-40 °C to +125 °C	DIP14	plastic dual in-line package; 14 leads (300 mil)	SOT27-1
74HCT164D	-40 °C to +125 °C	SO14	plastic small outline package; 14 leads; body width 3.9 mm; body thickness 1.47 mm	SOT108-2

Table 3: Pin description ...continued

Symbol	Pin	Description
GND	7	ground (0 V)
CP	8	clock input (LOW-to-HIGH, edge-triggered)
$\overline{\text{MR}}$	9	master reset input (active LOW)
Q4	10	output
Q5	11	output
Q6	12	output
Q7	13	output
V <sub>CC</sub>	14	positive supply voltage

## 7. Functional description

### 7.1 Function selection

Table 4: Function table [1]

Operating modes	Input				Output	
	$\overline{\text{MR}}$	CP	DSA	DSB	Q0	Q1 to Q7
Reset (clear)	L	X	X	X	L	L to L
Shift	H	↑	l	l	L	q0 to q6
	H	↑	l	h	L	q0 to q6
	H	↑	h	l	L	q0 to q6
	H	↑	h	h	H	q0 to q6

- [1] H = HIGH voltage level  
 h = HIGH voltage level one set-up time prior to the LOW-to-HIGH clock transition  
 L = LOW voltage level  
 l = LOW voltage level one set-up time prior to the LOW-to-HIGH clock transition  
 q = lower case letters indicate the state of the referenced input one set-up time prior to the LOW-to-HIGH clock transition  
 ↑ = LOW-to-HIGH clock transition

## 8. Limiting values

Table 5: Limiting values

In accordance with the Absolute Maximum Rating System (IEC 60134). Voltages are referenced to GND (ground = 0 V).

Symbol	Parameter	Conditions	Min	Max	Unit
V <sub>CC</sub>	supply voltage		-0.5	+7	V
I <sub>IK</sub>	input diode current	V <sub>I</sub> < -0.5 V or V <sub>I</sub> > V <sub>CC</sub> + 0.5 V	-	±20	mA
I <sub>OK</sub>	output diode current	V <sub>O</sub> < -0.5 V or V <sub>O</sub> > V <sub>CC</sub> + 0.5 V	-	±20	mA
I <sub>O</sub>	output source or sink current	V <sub>O</sub> = -0.5 V to V <sub>CC</sub> + 0.5 V	-	±25	mA
I <sub>CC</sub> , I <sub>GND</sub>	V <sub>CC</sub> or GND current		-	±50	mA
T <sub>stg</sub>	storage temperature		-65	+150	°C

**Table 5: Limiting values ...continued**

In accordance with the Absolute Maximum Rating System (IEC 60134). Voltages are referenced to GND (ground = 0 V).

Symbol	Parameter	Conditions	Min	Max	Unit
P <sub>tot</sub>	total power dissipation				
	DIP14 package		[1] -	750	mW
	SO14; SSOP14; TSSOP14; DHVQFN14 package		[2] -	500	mW

[1] For DIP14 packages: P<sub>tot</sub> derates linearly with 12 mW/K above 70 °C.

[2] For SO14 packages: P<sub>tot</sub> derates linearly with 8 mW/K above 70 °C.

For SSOP14 and TSSOP14 packages: P<sub>tot</sub> derates linearly with 5.5 mW/K above 60 °C.

For DHVQFN14 packages: P<sub>tot</sub> derates linearly with 4.5 mW/K above 60 °C.

## 9. Recommended operating conditions

**Table 6: Recommended operating conditions**

Symbol	Parameter	Conditions	Min	Typ	Max	Unit
<b>Type 74HC164</b>						
V <sub>CC</sub>	supply voltage		2.0	5.0	6.0	V
V <sub>I</sub>	input voltage		0	-	V <sub>CC</sub>	V
V <sub>O</sub>	output voltage		0	-	V <sub>CC</sub>	V
t <sub>r</sub> , t <sub>f</sub>	input rise and fall time	V <sub>CC</sub> = 2.0 V	-	-	1000	ns
		V <sub>CC</sub> = 4.5 V	-	6.0	500	ns
		V <sub>CC</sub> = 6.0 V	-	-	400	ns
T <sub>amb</sub>	ambient temperature		-40	-	+125	°C
<b>Type 74HCT164</b>						
V <sub>CC</sub>	supply voltage		4.5	5.0	6.0	V
V <sub>I</sub>	input voltage		0	-	V <sub>CC</sub>	V
V <sub>O</sub>	output voltage		0	-	V <sub>CC</sub>	V
t <sub>r</sub> , t <sub>f</sub>	input rise and fall time	V <sub>CC</sub> = 4.5 V	-	6.0	500	ns
T <sub>amb</sub>	ambient temperature		-40	-	+125	°C

## 10. Static characteristics

**Table 7: Static characteristics for 74HC164**

At recommended operating conditions; voltages are referenced to GND (ground = 0 V).

Symbol	Parameter	Conditions	Min	Typ	Max	Unit
<b>T<sub>amb</sub> = 25 °C</b>						
V <sub>IH</sub>	HIGH-level input voltage	V <sub>CC</sub> = 2.0 V	1.5	1.2	-	V
		V <sub>CC</sub> = 4.5 V	3.15	2.4	-	V
		V <sub>CC</sub> = 6.0 V	4.2	3.2	-	V

**Table 7: Static characteristics for 74HC164 ...continued**  
 At recommended operating conditions; voltages are referenced to GND (ground = 0 V).

Symbol	Parameter	Conditions	Min	Typ	Max	Unit
V <sub>IL</sub>	LOW-level input voltage	V <sub>CC</sub> = 2.0 V	-	0.8	0.5	V
		V <sub>CC</sub> = 4.5 V	-	2.1	1.35	V
		V <sub>CC</sub> = 6.0 V	-	2.8	1.8	V
V <sub>OH</sub>	HIGH-level output voltage	V <sub>I</sub> = V <sub>IH</sub> or V <sub>IL</sub>				
		I <sub>O</sub> = -20 μA; V <sub>CC</sub> = 2.0 V	1.9	2.0	-	V
		I <sub>O</sub> = -20 μA; V <sub>CC</sub> = 4.5 V	4.4	4.5	-	V
		I <sub>O</sub> = -20 μA; V <sub>CC</sub> = 6.0 V	5.9	6.0	-	V
		I <sub>O</sub> = -4 mA; V <sub>CC</sub> = 4.5 V	3.98	4.32	-	V
		I <sub>O</sub> = -5.2 mA; V <sub>CC</sub> = 6.0 V	5.48	5.81	-	V
V <sub>OL</sub>	LOW-level output voltage	V <sub>I</sub> = V <sub>IH</sub> or V <sub>IL</sub>				
		I <sub>O</sub> = 20 μA; V <sub>CC</sub> = 2.0 V	-	0	0.1	V
		I <sub>O</sub> = 20 μA; V <sub>CC</sub> = 4.5 V	-	0	0.1	V
		I <sub>O</sub> = 20 μA; V <sub>CC</sub> = 6.0 V	-	0	0.1	V
		I <sub>O</sub> = 4 mA; V <sub>CC</sub> = 4.5 V	-	0.15	0.26	V
		I <sub>O</sub> = 5.2 mA; V <sub>CC</sub> = 6.0 V	-	0.16	0.26	V
I <sub>LI</sub>	input leakage current	V <sub>I</sub> = V <sub>CC</sub> or GND; V <sub>CC</sub> = 6.0 V	-	-	±0.1	μA
I <sub>CC</sub>	quiescent supply current	V <sub>I</sub> = V <sub>CC</sub> or GND; I <sub>O</sub> = 0 A; V <sub>CC</sub> = 6.0 V	-	-	8.0	μA
C <sub>I</sub>	input capacitance		-	3.5	-	pF
<b>T<sub>amb</sub> = -40 °C to +85 °C</b>						
V <sub>IH</sub>	HIGH-level input voltage	V <sub>CC</sub> = 2.0 V	1.5	-	-	V
		V <sub>CC</sub> = 4.5 V	3.15	-	-	V
		V <sub>CC</sub> = 6.0 V	4.2	-	-	V
V <sub>IL</sub>	LOW-level input voltage	V <sub>CC</sub> = 2.0 V	-	-	0.5	V
		V <sub>CC</sub> = 4.5 V	-	-	1.35	V
		V <sub>CC</sub> = 6.0 V	-	-	1.8	V
V <sub>OH</sub>	HIGH-level output voltage	V <sub>I</sub> = V <sub>IH</sub> or V <sub>IL</sub>				
		I <sub>O</sub> = -20 μA; V <sub>CC</sub> = 2.0 V	1.9	-	-	V
		I <sub>O</sub> = -20 μA; V <sub>CC</sub> = 4.5 V	4.4	-	-	V
		I <sub>O</sub> = -20 μA; V <sub>CC</sub> = 6.0 V	5.9	-	-	V
		I <sub>O</sub> = -4 mA; V <sub>CC</sub> = 4.5 V	3.84	-	-	V
		I <sub>O</sub> = -5.2 mA; V <sub>CC</sub> = 6.0 V	5.34	-	-	V
V <sub>OL</sub>	LOW-level output voltage	V <sub>I</sub> = V <sub>IH</sub> or V <sub>IL</sub>				
		I <sub>O</sub> = 20 μA; V <sub>CC</sub> = 2.0 V	-	-	0.1	V
		I <sub>O</sub> = 20 μA; V <sub>CC</sub> = 4.5 V	-	-	0.1	V
		I <sub>O</sub> = 20 μA; V <sub>CC</sub> = 6.0 V	-	-	0.1	V
		I <sub>O</sub> = 4 mA; V <sub>CC</sub> = 4.5 V	-	-	0.33	V
		I <sub>O</sub> = 5.2 mA; V <sub>CC</sub> = 6.0 V	-	-	0.33	V
I <sub>LI</sub>	input leakage current	V <sub>I</sub> = V <sub>CC</sub> or GND; V <sub>CC</sub> = 6.0 V	-	-	±1.0	μA
I <sub>CC</sub>	quiescent supply current	V <sub>I</sub> = V <sub>CC</sub> or GND; I <sub>O</sub> = 0 A; V <sub>CC</sub> = 6.0 V	-	-	80	μA

**Table 7: Static characteristics for 74HC164 ...continued**

At recommended operating conditions; voltages are referenced to GND (ground = 0 V).

Symbol	Parameter	Conditions	Min	Typ	Max	Unit
<b>T<sub>amb</sub> = -40 °C to +125 °C</b>						
V <sub>IH</sub>	HIGH-level input voltage	V <sub>CC</sub> = 2.0 V	1.5	-	-	V
		V <sub>CC</sub> = 4.5 V	3.15	-	-	V
		V <sub>CC</sub> = 6.0 V	4.2	-	-	V
V <sub>IL</sub>	LOW-level input voltage	V <sub>CC</sub> = 2.0 V	-	-	0.5	V
		V <sub>CC</sub> = 4.5 V	-	-	1.35	V
		V <sub>CC</sub> = 6.0 V	-	-	1.8	V
V <sub>OH</sub>	HIGH-level output voltage	V <sub>I</sub> = V <sub>IH</sub> or V <sub>IL</sub>		-		
		I <sub>O</sub> = -20 μA; V <sub>CC</sub> = 2.0 V	1.9	-	-	V
		I <sub>O</sub> = -20 μA; V <sub>CC</sub> = 4.5 V	4.4	-	-	V
		I <sub>O</sub> = -20 μA; V <sub>CC</sub> = 6.0 V	5.9	-	-	V
		I <sub>O</sub> = -4 mA; V <sub>CC</sub> = 4.5 V	3.7	-	-	V
		I <sub>O</sub> = -5.2 mA; V <sub>CC</sub> = 6.0 V	5.2	-	-	V
V <sub>OL</sub>	LOW-level output voltage	V <sub>I</sub> = V <sub>IH</sub> or V <sub>IL</sub>		-		
		I <sub>O</sub> = 20 μA; V <sub>CC</sub> = 2.0 V	-	-	0.1	V
		I <sub>O</sub> = 20 μA; V <sub>CC</sub> = 4.5 V	-	-	0.1	V
		I <sub>O</sub> = 20 μA; V <sub>CC</sub> = 6.0 V	-	-	0.1	V
		I <sub>O</sub> = 4 mA; V <sub>CC</sub> = 4.5 V	-	-	0.4	V
		I <sub>O</sub> = 5.2 mA; V <sub>CC</sub> = 6.0 V	-	-	0.4	V
I <sub>LI</sub>	input leakage current	V <sub>I</sub> = V <sub>CC</sub> or GND; V <sub>CC</sub> = 6.0 V	-	-	±1.0	μA
I <sub>CC</sub>	quiescent supply current	V <sub>I</sub> = V <sub>CC</sub> or GND; I <sub>O</sub> = 0 A; V <sub>CC</sub> = 6.0 V	-	-	160	μA

**Table 8: Static characteristics for 74HCT164**

At recommended operating conditions; voltages are referenced to GND (ground = 0 V).

Symbol	Parameter	Conditions	Min	Typ	Max	Unit
<b>T<sub>amb</sub> = 25 °C</b>						
V <sub>IH</sub>	HIGH-level input voltage	V <sub>CC</sub> = 4.5 V to 5.5 V	2.0	1.6	-	V
V <sub>IL</sub>	LOW-level input voltage	V <sub>CC</sub> = 4.5 V to 5.5 V	-	1.2	0.8	V
V <sub>OH</sub>	HIGH-level output voltage	V <sub>I</sub> = V <sub>IH</sub> or V <sub>IL</sub>				
		I <sub>O</sub> = -20 μA; V <sub>CC</sub> = 4.5 V	4.4	4.5	-	V
		I <sub>O</sub> = -4 mA; V <sub>CC</sub> = 4.5 V	3.98	4.32	-	V
V <sub>OL</sub>	LOW-level output voltage	V <sub>I</sub> = V <sub>IH</sub> or V <sub>IL</sub>				
		I <sub>O</sub> = 20 μA; V <sub>CC</sub> = 4.5 V	-	0	0.1	V
		I <sub>O</sub> = 4 mA; V <sub>CC</sub> = 4.5 V	-	0.15	0.26	V
I <sub>LI</sub>	input leakage current	V <sub>I</sub> = V <sub>CC</sub> or GND; V <sub>CC</sub> = 5.5 V	-	-	±0.1	μA
I <sub>CC</sub>	quiescent supply current	V <sub>I</sub> = V <sub>CC</sub> or GND; I <sub>O</sub> = 0 A; V <sub>CC</sub> = 5.5 V	-	-	8.0	μA
ΔI <sub>CC</sub>	additional quiescent supply current per input pin	V <sub>I</sub> = V <sub>CC</sub> - 2.1 V; other inputs V <sub>I</sub> = V <sub>CC</sub> or GND; V <sub>CC</sub> = 4.5 V to 5.5 V; I <sub>O</sub> = 0 A	-	100	360	μA
C <sub>I</sub>	input capacitance		-	3.5	-	pF

**Table 8: Static characteristics for 74HCT164 ...continued**

At recommended operating conditions; voltages are referenced to GND (ground = 0 V).

Symbol	Parameter	Conditions	Min	Typ	Max	Unit
<b><math>T_{amb} = -40\text{ °C to }+85\text{ °C}</math></b>						
$V_{IH}$	HIGH-level input voltage	$V_{CC} = 4.5\text{ V to }5.5\text{ V}$	2.0	-	-	V
$V_{IL}$	LOW-level input voltage	$V_{CC} = 4.5\text{ V to }5.5\text{ V}$	-	-	0.8	V
$V_{OH}$	HIGH-level output voltage	$V_I = V_{IH}\text{ or }V_{IL}$				
		$I_O = -20\text{ }\mu\text{A}; V_{CC} = 4.5\text{ V}$	4.4	-	-	V
		$I_O = -4\text{ mA}; V_{CC} = 4.5\text{ V}$	3.84	-	-	V
$V_{OL}$	LOW-level output voltage	$V_I = V_{IH}\text{ or }V_{IL}$				
		$I_O = 20\text{ }\mu\text{A}; V_{CC} = 4.5\text{ V}$	-	-	0.1	V
		$I_O = 4\text{ mA}; V_{CC} = 4.5\text{ V}$	-	-	0.33	V
$I_{LI}$	input leakage current	$V_I = V_{CC}\text{ or GND}; V_{CC} = 5.5\text{ V}$	-	-	$\pm 1.0$	$\mu\text{A}$
$I_{CC}$	quiescent supply current	$V_I = V_{CC}\text{ or GND}; I_O = 0\text{ A}; V_{CC} = 5.5\text{ V}$	-	-	80.0	$\mu\text{A}$
$\Delta I_{CC}$	additional quiescent supply current per input pin	$V_I = V_{CC} - 2.1\text{ V};$ other inputs $V_I = V_{CC}\text{ or GND};$ $V_{CC} = 4.5\text{ V to }5.5\text{ V}; I_O = 0\text{ A}$	-	-	450	$\mu\text{A}$
<b><math>T_{amb} = -40\text{ °C to }+125\text{ °C}</math></b>						
$V_{IH}$	HIGH-level input voltage	$V_{CC} = 4.5\text{ V to }5.5\text{ V}$	2.0	-	-	V
$V_{IL}$	LOW-level input voltage	$V_{CC} = 4.5\text{ V to }5.5\text{ V}$	-	-	0.8	V
$V_{OH}$	HIGH-level output voltage	$V_I = V_{IH}\text{ or }V_{IL}$				
		$I_O = -20\text{ }\mu\text{A}; V_{CC} = 4.5\text{ V}$	4.4	-	-	V
		$I_O = -4\text{ mA}; V_{CC} = 4.5\text{ V}$	3.7	-	-	V
$V_{OL}$	LOW-level output voltage	$V_I = V_{IH}\text{ or }V_{IL}$				
		$I_O = 20\text{ }\mu\text{A}; V_{CC} = 4.5\text{ V}$	-	-	0.1	V
		$I_O = 4\text{ mA}; V_{CC} = 4.5\text{ V}$	-	-	0.4	V
$I_{LI}$	input leakage current	$V_I = V_{CC}\text{ or GND}; V_{CC} = 5.5\text{ V}$	-	-	$\pm 1.0$	$\mu\text{A}$
$I_{CC}$	quiescent supply current	$V_I = V_{CC}\text{ or GND}; I_O = 0\text{ A}; V_{CC} = 5.5\text{ V}$	-	-	160.0	$\mu\text{A}$
$\Delta I_{CC}$	additional quiescent supply current per input pin	$V_I = V_{CC} - 2.1\text{ V};$ other inputs $V_I = V_{CC}\text{ or GND};$ $V_{CC} = 4.5\text{ V to }5.5\text{ V}; I_O = 0\text{ A}$	-	-	490	$\mu\text{A}$

**Table 10: Dynamic characteristics for 74HCT164**

$GND = 0\text{ V}$ ;  $t_r = t_f = 6\text{ ns}$ ;  $C_L = 50\text{ pF}$ ; test circuit see [Figure 10](#); unless otherwise specified

Symbol	Parameter	Conditions	Min	Typ	Max	Unit
<b><math>T_{amb} = 25\text{ °C}</math></b>						
$t_{PHL}, t_{PLH}$	propagation delay CP to Qn	$V_{CC} = 4.5\text{ V}$ ; see <a href="#">Figure 7</a>	-	17	36	ns
$t_{PHL}$	propagation delay $\overline{MR}$ to Qn	$V_{CC} = 4.5\text{ V}$ ; see <a href="#">Figure 8</a>	-	19	38	ns
$t_{THL}, t_{TLH}$	output transition time	$V_{CC} = 4.5\text{ V}$ ; see <a href="#">Figure 7</a>	-	7	15	ns
$t_W$	clock pulse width; HIGH or LOW	$V_{CC} = 4.5\text{ V}$ ; see <a href="#">Figure 7</a>	18	7	-	ns
	master reset pulse width; LOW	$V_{CC} = 4.5\text{ V}$ ; see <a href="#">Figure 8</a>	18	10	-	ns
$t_{rem}$	removal time $\overline{MR}$ to CP	$V_{CC} = 4.5\text{ V}$ ; see <a href="#">Figure 8</a>	16	7	-	ns
$t_{su}$	set-up time DSA, and DSB to CP	$V_{CC} = 4.5\text{ V}$ ; see <a href="#">Figure 9</a>	12	6	-	ns
$t_h$	hold time DSA, and DSB to CP	$V_{CC} = 4.5\text{ V}$ ; see <a href="#">Figure 9</a>	+4	-2	-	ns
$f_{max}$	maximum clock pulse frequency	$V_{CC} = 4.5\text{ V}$ ; see <a href="#">Figure 7</a>	27	55	-	MHz
<b><math>T_{amb} = -40\text{ °C to }+85\text{ °C}</math></b>						
$t_{PHL}, t_{PLH}$	propagation delay CP to Qn	$V_{CC} = 4.5\text{ V}$ ; see <a href="#">Figure 7</a>	-	-	45	ns
$t_{PHL}$	propagation delay $\overline{MR}$ to Qn	$V_{CC} = 4.5\text{ V}$ ; see <a href="#">Figure 8</a>	-	-	48	ns
$t_{THL}, t_{TLH}$	output transition time	$V_{CC} = 4.5\text{ V}$ ; see <a href="#">Figure 7</a>	-	-	19	ns
$t_W$	clock pulse width; HIGH or LOW	$V_{CC} = 4.5\text{ V}$ ; see <a href="#">Figure 7</a>	23	-	-	ns
	master reset pulse width; LOW	$V_{CC} = 4.5\text{ V}$ ; see <a href="#">Figure 8</a>	23	-	-	ns
$t_{rem}$	removal time $\overline{MR}$ to CP	$V_{CC} = 4.5\text{ V}$ ; see <a href="#">Figure 8</a>	20	-	-	ns
$t_{su}$	set-up time DSA, and DSB to CP	$V_{CC} = 4.5\text{ V}$ ; see <a href="#">Figure 9</a>	15	-	-	ns
$t_h$	hold time DSA, and DSB to CP	$V_{CC} = 4.5\text{ V}$ ; see <a href="#">Figure 9</a>	4	-	-	ns
$f_{max}$	maximum clock pulse frequency	$V_{CC} = 4.5\text{ V}$ ; see <a href="#">Figure 7</a>	22	-	-	MHz
<b><math>T_{amb} = -40\text{ °C to }+125\text{ °C}</math></b>						
$t_{PHL}, t_{PLH}$	propagation delay CP to Qn	$V_{CC} = 4.5\text{ V}$ ; see <a href="#">Figure 7</a>	-	-	54	ns
$t_{PHL}$	propagation delay $\overline{MR}$ to Qn	$V_{CC} = 4.5\text{ V}$ ; see <a href="#">Figure 8</a>	-	-	57	ns
$t_{THL}, t_{TLH}$	output transition time	$V_{CC} = 4.5\text{ V}$ ; see <a href="#">Figure 7</a>	-	-	22	ns



**Table 10: Dynamic characteristics for 74HCT164 ...continued**

$GND = 0\text{ V}$ ;  $t_r = t_f = 6\text{ ns}$ ;  $C_L = 50\text{ pF}$ ; test circuit see [Figure 10](#); unless otherwise specified

Symbol	Parameter	Conditions	Min	Typ	Max	Unit
$t_w$	clock pulse width; HIGH or LOW	$V_{CC} = 4.5\text{ V}$ ; see <a href="#">Figure 7</a>	27	-	-	ns
	master reset pulse width; LOW	$V_{CC} = 4.5\text{ V}$ ; see <a href="#">Figure 8</a>	27	-	-	ns
$t_{rem}$	removal time $\overline{MR}$ to CP	$V_{CC} = 4.5\text{ V}$ ; see <a href="#">Figure 8</a>	24	-	-	ns
$t_{su}$	set-up time DSA and DSB to CP	$V_{CC} = 4.5\text{ V}$ ; see <a href="#">Figure 9</a>	18	-	-	ns
$t_h$	hold time DSA and DSB to CP	$V_{CC} = 4.5\text{ V}$ ; see <a href="#">Figure 9</a>	4	-	-	ns
$f_{max}$	maximum clock pulse frequency	$V_{CC} = 4.5\text{ V}$ ; see <a href="#">Figure 7</a>	18	-	-	MHz

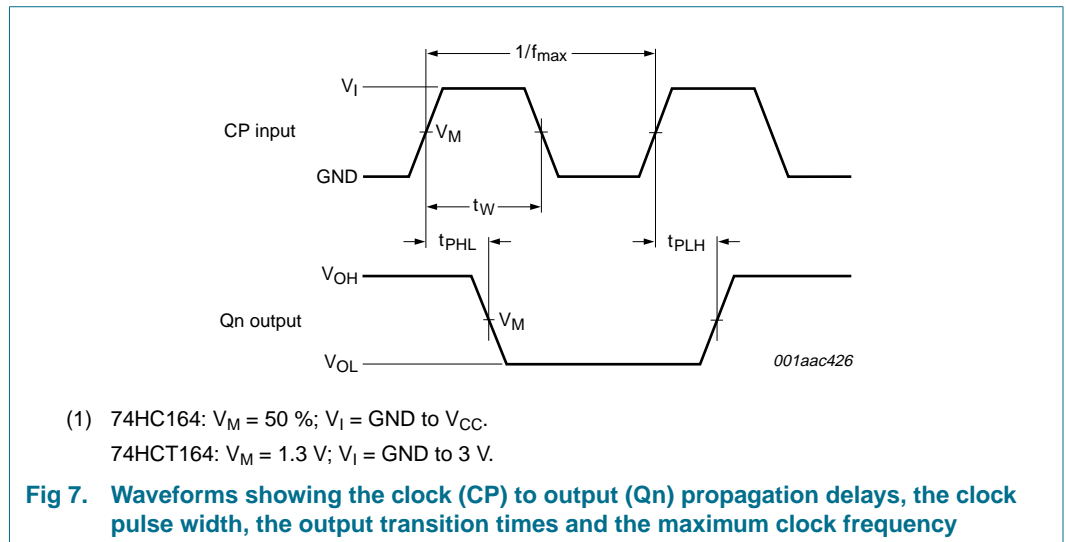

12. Package outline

DIP14: plastic dual in-line package; 14 leads (300 mil)

SOT27-1

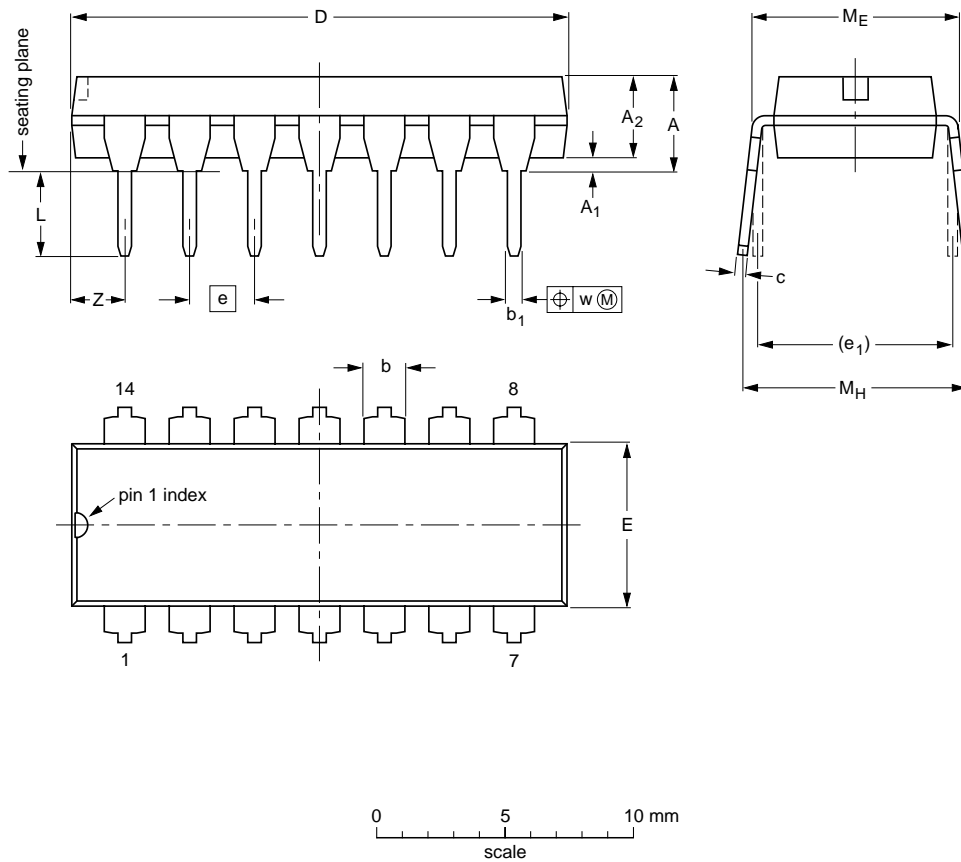

DIMENSIONS (inch dimensions are derived from the original mm dimensions)

UNIT	A max.	A <sub>1</sub> min.	A <sub>2</sub> max.	b	b <sub>1</sub>	c	D <sup>(1)</sup>	E <sup>(1)</sup>	e	e <sub>1</sub>	L	M <sub>E</sub>	M <sub>H</sub>	w	Z <sup>(1)</sup> max.
mm	4.2	0.51	3.2	1.73 1.13	0.53 0.38	0.36 0.23	19.50 18.55	6.48 6.20	2.54	7.62	3.60 3.05	8.25 7.80	10.0 8.3	0.254	2.2
inches	0.17	0.02	0.13	0.068 0.044	0.021 0.015	0.014 0.009	0.77 0.73	0.26 0.24	0.1	0.3	0.14 0.12	0.32 0.31	0.39 0.33	0.01	0.087

Note

1. Plastic or metal protrusions of 0.25 mm (0.01 inch) maximum per side are not included.

OUTLINE VERSION	REFERENCES			EUROPEAN PROJECTION
	IEC	JEDEC	JEITA	
SOT27-1	050G04	MO-001	SC-501-14	

Fig 11. Package outline SOT27-1 (DIP14)